

Analytical / Precision
ELECTRONIC BALANCE

We ware try the best to ensure the veracity of operating manual, but we didn't take responsibility for printing or description mistake.

We has right to update the machine looking and performance without noticing the consumer.

<i>CONTENTS</i>	<i>PAGE</i>
Warming And Safety Using	2
First Part: Summarize	3
Second Part: Installation	6
Third Part: Basic Operating	8
Basic Weighing Function	8
Calibration / Adjustment	8
Fourth Part: Operate Application	10
Counting Function	10
Percentage Weighing	10
Accumulating	11
Peak Holding	11
Dynamic Weighing	12
High Low Limit Alarm	13
Fifth Part: Basic Function Setting	14
Turn On/Off Units	14
Temperature Setting	15
Backlight Setting	15
Buzzer Setting	16
Dormancy and Power Saving Setting	17
Power On Self Test Setting	17
Sixth Part: Communication Setting	18
Turn On/Off Output Data Setting	20
Printing Data Format Setting	22
Seventh Part: Weighing Performance Setting	23
Eighth Part: Restore Factory Setting	24
Ninth Part: Unit Switching	25
Tenth Part: Specification	26
Eleventh Part: Proper Care and Maintenance	28

SAFETY

- For avoiding damage, please read all operating instructions carefully before use.
- ⚠ Don't use your machine under dangerous working circumstance.
- ⚠ Cut off the power if machine will turn off for more than one week.
- ⚠ Turn off the machine and cut off the power before or after connection with other equipments.
- ⚠ Strong magnetic field and static electricity can have an adverse effect on weighing sensor. When disturbance disappear, the machine will work well again.

Warning

- All our parts is the most suitable parts for machine.
All modification or using unauthorized parts for machine need to be confirm before using.
All modification needs to be take responsibility.
- Do not open the machine housing. Machine will not have guarantee service if security label broken.

1. Unpacking

- After unpacking the machine, please check machine has any visible damage.
- Please keep the original box and packing material for storing machine when not in use or send back for repairing.
Before packing the balance, please cut off all power and cable.

2. Packing List

Machine Item	Main Machine	Weight Mass	Adapter	Cable	Pan	Operating Manual
	1pc	1-2pcs	1pc	1pc	1Set (2pcs)	1pc
		1pc		Non-		
		Non-				

3. Installation

- When select the location for install machine, please keep these tips in mind:
- Do not put machine close to central heating or sunshine and airflow way.
(Opening door or window)
 - Do not exposure machine to extreme heat or cold. Keep scale in a clean, dry location. Dust, dirt and moisture can accumulate on the weighing sensor.
 - Install machine on a flat and level surface, free from vibration and drafts, free from corrosive and strong magnetic field, as they can have an adverse effect on the weighing sensors.

4. Warm up for machine adapt temperature

When move machine from high temperature place to low temperature place (or inversely), please keep machine in final place for two hours and then turn on to warm up (warm up time refer to the specification list), as the machine will proportion the room temperature.

Summarize

5. Key Explanation

UNIT KEY (Move Key)

- A: Select Unit.
 B: Status 1: Move the flash on digit to left.
 C: Status 2: When all digit flash, press UNIT KEY and let single digit flash, enter into status 1. Press UNIT KEY again enter into status 2. It is circle.
 D: Status 3: When set parameter, press UNIT KEY can minus one. (At this moment)
 E: The shortcut key of accumulation, press and hold this key can enter into accumulation function.

MENU KEY

- A: Press and Hold MENU KEY for 5 seconds will enter into system setting menu.
 B: Press and Hold MENU KEY for 1 second will save and quit system setting menu.
 C: Short press MENU KEY to alternately display system menu, but if only one parameter in this level, short press MENU KEY will return to previous menu.

CAL KEY (Enter Key/Confirm Key)

- A: When normal weighing, short press CAL KEY will zeroing.
 B: Press and hold CAL KEY for 5 seconds will enter into calibration.
 C: Enter into submenu.
 D: At the bottom menu, press CAL KEY will confirm the present status and return to: (1) The previous menu
 (2) Enter into a weighing function (such as density, dynamic)
 E: Under COD STATUS (Engineer Parameter Setting Status) Input different code will enter into correspond parameter menu.

PRINT KEY (Circle Key)

- A: When manual printing or communication available, press PRINT KEY will send weighing data to printer or other equipment.
 B: When one digit flash , press PRINT KEY will plus one.
 C: Cycle to next parameter when display flash.
 D: The shortcut key is dynamic weighing function. Press and hold this key can let machine enter into dynamic weighing.

TARE KEY (Return Key)

- A: Tare.
 B: Return to the previous menu without save.
 C: Press and hold PRINT KEY for 1 second will quit from a weighing function.
 D: The shortcut key of high-low limits alarm. Press and hold this key to enter into high-low limit alarm setting.

Note: The buzzer sound different when long press or short press the key.

6. Display Explanation

● F Series

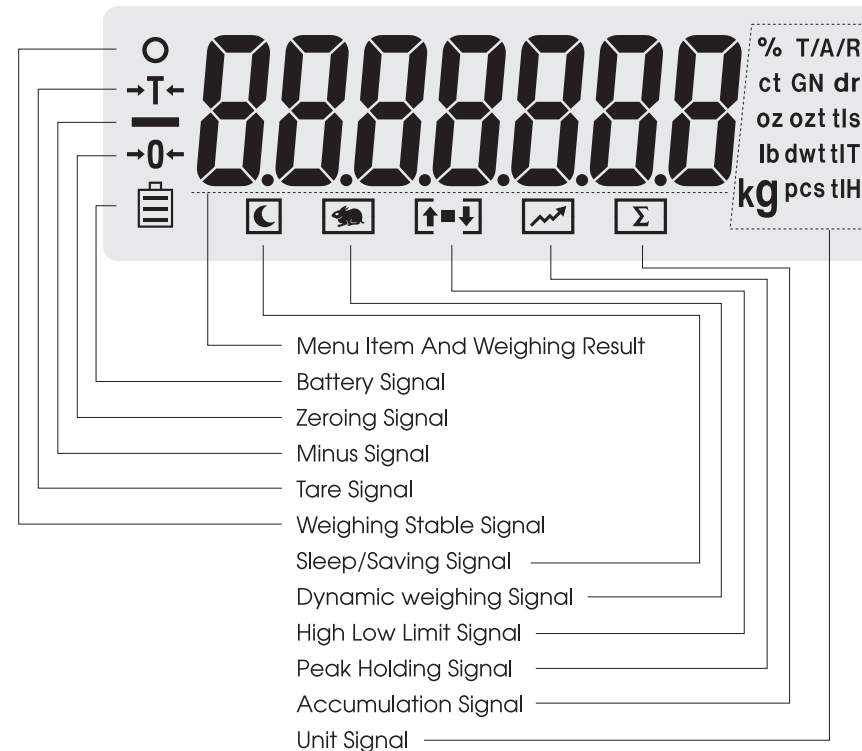

● T Series

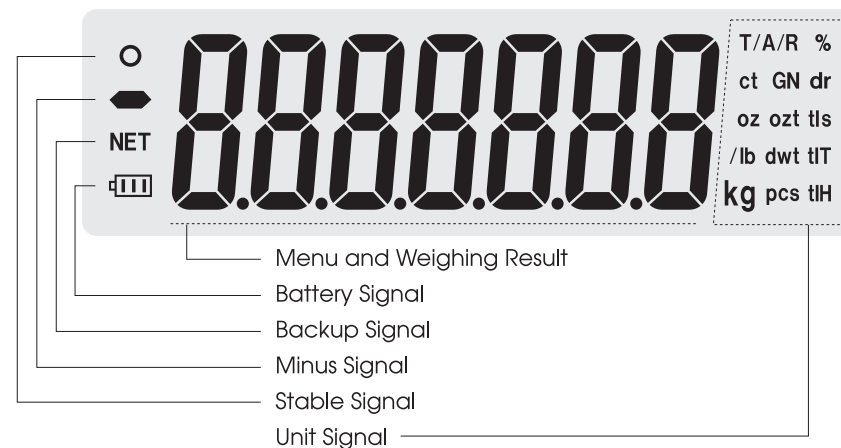

Second Part: Installation

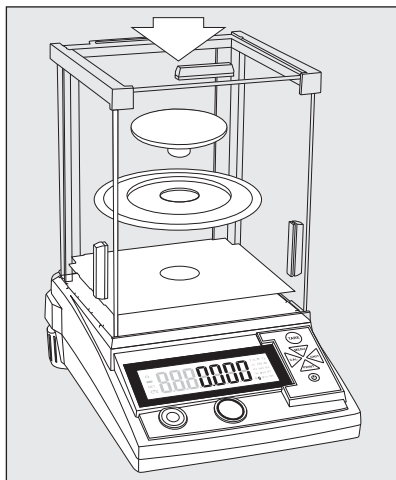

Assemble Machine

The machine with windshield

- Assemble each parts as following :
 - Air-free loop
 - Put weighing pan on the pillar which is in the middle of machine.

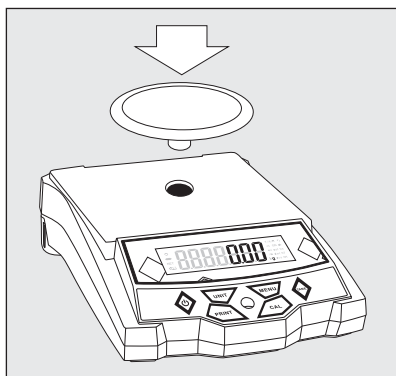

The machine with round weighing pan

- Put weighing pan on the pillar which is in the middle of machine.

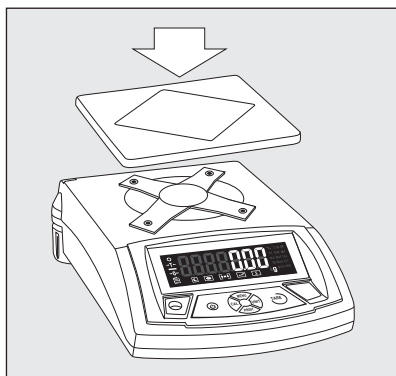

The machine with square weighing pan

- Put the weighing pan on bracket.

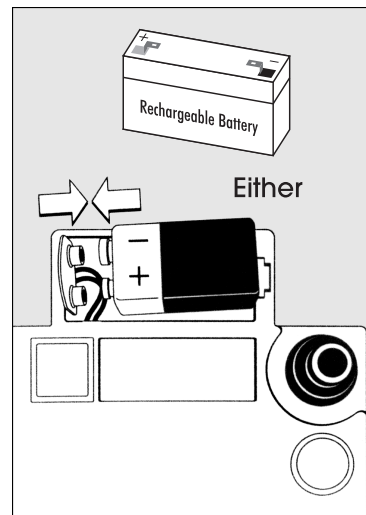

Use dry battery / Rechargeable battery (Optional)

- The dry battery or rechargeable battery is not on machine's packing list.
- ⚠ Only normal or universal 9V dry battery or rechargeable battery will be available for machine.
- ⚠ Only available for using adapter to recharge the rechargeable battery for machine.
- Lie down the machine at side.
- Open the battery box cover.
- Connect and put 9V dry battery or rechargeable battery in box.
- Confirm the positive and negative correctly.
- Close the battery box: Screw the battery box cover adown to the machine.
- ⚠ The used battery is recycled. According to the waste disposal law, rechargeable battery to be used as a special garbage recycling and specialized handling.

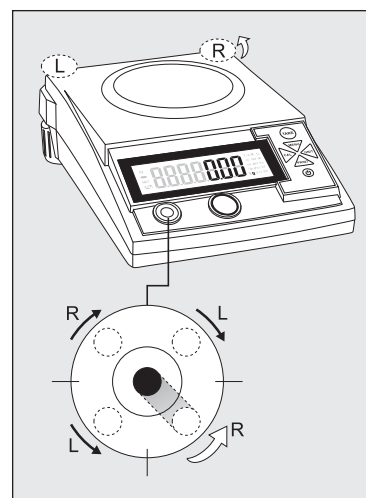

Adjust Machine Level

The machine need to adjust the level ever time when change the install location. Moving the two back screw nuts slowing to adjust level.

- Counterclockwise rotate the two back screws to right position.
- Rotate the screws as the photo until the bubble is in the middle of level device.
- Clockwise rotate the two back screws until it touch the supporter.
- > Under normal circumstances, adjust level need several times to reach suitable position.

Basic Weighing Function

Preparation



- Turn on machine: Press (ON/OFF) Key

Warm up time:

- For making sure the weighing result correct, different type machine need different warm up time to reach the required operating temperature. Please refer the specification list to know the correct warm up time.

INSTANCE

Basic Weighing (The machine was warm up)

Key (Order)	Step Explanation	LCD Screen Display
	1. Zero Stable	0.000 g
	2. Put container on weighing pan (Example: 100g)	100.00 g
[TARE]	3. Press Tare key for tare the container weight	0.00 g
	4. Put sample in container (Example: 200g)	200.00 g

Calibration / Adjustment

Request

The machine only can be Calibration / Adjustment in the following cases:



- Nothing on weighing pan, was tare, weighing signal stable

Machine will have ERRO SIGNAL if does not have above premise.

If all premise available, the machine will display required weight mass value for calibration.



INSTANCE (Example: F-A+200)

(1) External Span Calibration Instance

Key (Order)	Step Explanation	LCD Screen Display
[TARE]	1. Machine tare	0.000 g
Press and Hold [CAL] Key	2. Display span calibration signal Flash the required weight mass value: 200g	200.000 g
	3. Put required weight mass on pan. After 5 seconds, display the weight of it.	200.000 g
	4. Take the weight mass away (Span calibration finished)	0.000 g

(2) External Linearity Calibration Instance

(Please DO NOT linearity calibrate the machine if you don't have match weight mass)

Key (Order)	Step Explanation	LCD Screen Display
Short Press [TARE] Key	1. Machine tare	0.000 g
Press and Hold [CAL] Key for 5 seconds	2. Display Span CAL signal Flash 200g signal	200.000 g
Release [CAL] Key, Press and Hold [MENU] Key for 5 seconds	3. Display Linearity CAL signal Flash 100g signal	100.000 g
	4. Put required weight mass on pan Display 100g after 5 seconds	100.000 g
	5. Take weight mass away (Linearity calibration finished)	0.000 g

Note: The grey color words explain the signal's meaning which flash on the window.



Fourth Part: Operate Application

Application Setting

Counting

Use this function can calculate the quantity with total weight divide by signal weight.



Instance (With known the sample's quantity but unknown the unit weight)

Key (Order)	Step Explanation	LCD Screen Display
Short Press [MENU] Key	1. Enter into counting function and display flash the number of quantity ○ Short press [PRINT] key to cycle the sample quantity setting: 10, 20, 50, 100, 150, 200, 250, 500, 1000 pcs	
	2. Put any unknown numbers of pieces on pan (Example: set 20pcs)	20 pcs
Short Press [CAL] Key	3. The machine start to calculate and display quantity:20pcs	20 pcs
	4. Take sample away from pan	0 pcs
	5. Put any unknown numbers of pieces on pan and will display a count. (Example: 100pcs)	100 pcs
Short Press [MENU] Key	6. Exit the Counting Function	0.0000 g

Percentage Measurement

Operator place the reference sample that corresponds to 100% onto weighing pan, the other samples will display the weighing result as %.

Instance (Percentage Weighing)

Key (Order)	Step Explanation	LCD Screen Display
	1. Put sample on pan and machine will display the sample's weight (Example:90g)	90.0000 g
Short Press [UNIT] Key	2. Circle the unit to percentage signal: %, at machine will display 100%	100.000 %
	3. Take sample away and put any other sample on pan ○ Remove the reference sample and add the unknown sample to determine its relative weight and percentage.	79.000 %
Short Press [UNIT] Key	4. Exit the Percentage Measurement	0.0000 g



Note: The grey color words explain the signal's meaning which flash on the window.

Accumulation / Peak Holding Function

Accumulation Function (Not available for T series)

Weighing and accumulating the several sample's total weight and tracing the last time's data.



Instance

Key (Order)	Step Explanation	LCD Screen Display
Press and Hold [UNIT] Key	1. Enter into accumulation function and machine flash the signal	0.0000 g
	2. Put samples on pan	10.0000 g
Short Press [CAL] Key	3. Confirm and record the first weight ○ Example: 10g, the machine display weighing time:N01 and then display weight:10g.	10.0000 g
	4. Put sample several times and press [CAL] key each time to confirm and record the weight ○ Example: weigh 3 time, each weight are: 10g, 20g, 30g. The machine display total weight 60g. ○ Under the accumulate mode, the accumulate weight can be: 999.9999g(0.1mg), 9999.999g(1mg), 99999.99g(0.01g), 999999.9g(0.1g), 9999999g(1g) ○ Press and hold [CAL] key can check the last weighing data of accumulating.	60.0000 g
Press and Hold [CAL] Key	5. Clear the present accumulating and restart a new accumulate weighing	0.0000 g
Press and Hold [UNIT] Key	6. Exit the Accumulation Function	

Peak Holding (Optional function for F series, not available for T series)

Sensing the max weight during weighing, hold and display it.

Instance

Key (Order)	Step Explanation	LCD Screen Display
Press and Hold [MENU]&[UNIT] Key for 5 seconds at the same time	1. Enter into Peak holding menu and flash the signal at the same time	0.0000 g
	2. Put sample on pan (example:10g)	10.0000 g
	3. Put other sample on pan several times ○ Example: put 3 times , each weight is 10g, 13g, 12g. The machine will only display the max weight:13g	13.0000 g
Short Press [MENU]&[UNIT] Key at the same time	4. Clear the present Peak holding and restart a new Peak holding	0.0000 g
Press and Hold [MENU]&[UNIT] Key for 5 seconds at the same time	5. Exit the Peak Holding Function	

Note: The grey color words explain the signal's meaning which flash on the window.







Dynamic Measurement (Optional function for F series, not available for T series)

Purpose

Operator can use this program to measure dynamic weight. The dynamic weighing way is summarize the weighing result from setting time and average it.

Instance

Set 10 seconds for the dynamic weight material or variable weight material.

Key (Order)	Step Explanation	LCD Screen Display
Press and Hole [PRINT] Key	1. Enter into Peak holding menu and flash the signal and weighing time ○ The max weighing time is 59 seconds, setting way: Press [UNIT] to move the digit and [PRINT] key to increase the value.	
Short Press [CAL] Key	2. Confirm the weighing time and then display will flash: Start	
	3. Put dynamic sample on pan	
Short Press [CAL] Key	4. Machine start to weigh for 10 seconds	
	5. Average the weighing result automatically after 10 seconds ○ The machine displays the value. (Example: 98.423g)	
Short Press [TARE] Key	6. Clear the present weighing data ○ If need to measure the different sample, please repeat step 3~6.	
Press and Hole [PRINT] Key	7. Exit the Dynamic Weighing	









Note: The grey color words explain the signal's meaning which flash on the window.

High Low Limit Alarm Function (Not available for T series)

Purpose

Weighing the target sample's weight or quantity in or out the setting limit and alarm.

Instance (Example: F-A+200)

Key (Order)	Step Explanation	LCD Screen Display
Press and Hole [TARE] Key	1. Enter into the function menu The display flash OFF (To mention the function invalid)	
Short Press [PRINT] Key	2. The machine display ALR and flash IN (means alarm in limits) ○ Press [PRINT] key to select IN (in the limit) or OUT (out the limit). Press [CAL] key to confirm the setting. The machine will sound "Beep" if the sample's weight in the setting limit. The machine will sound "Beep" if the sample's weight out the setting limit.	
Short Press [CAL] Key	3. Setting the High Limit (Example: 200g and alarm in the limit) ○ The machine will display ALRH shortly to mention to set the high limit. Setting way is: Press [UNIT] key to move digit, press [PRINT] key to circle and select the value, and then press [CAL] to confirm the setting.	
Short Press [CAL] Key	4. Setting Low limit (Example: 180g and alarm in the limit) ○ The machine will display ALRH shortly to mention to set the high limit. Setting way is: Press [UNIT] key to move digit, press [PRINT] key to circle and select the value, and then press [CAL] to confirm the setting.	
	5. Put sample on pan (example:186g) ○ The machine display the sample's weight. The machine will sound "Beep" at the same time to mention that sample's weigh is in the setting limit. ○ If the sample's weighing over than the limit, machine will not sound but will flash up "↑" signal If the sample's weighing less than the limit, machine will not sound but will flash down "↓" signal.	
	6. Take sample away and machine flash down "↓" signal	
Press and Hole [TARE] Key	7. Exit the High Low Limit Alarm Function	

Note: The grey color words explain the signal's meaning which flash on the window.

Basic Function Setting

Purpose

Operator can set machine basic function by selecting parameter in Menu.

Turn On/Off the Units

Operator can turn on or off the unit to display or hide the relative weighing units.

Instance Key (Order)	Step Explanation	LCD Screen Display
Press and Hold [MENU] Key	1. Display the menu	--BASE-
Short Press [CAL] Key	2. Enter into setting menu	-SCALE-
Short Press [MENU] Key	3. Enter into turn on/off menu	--UNIT-
Short Press [CAL] Key	4. Display unit: ct and flash ON (Enable)	ct - ON ct
Short Press [PRINT] Key	5. Display unit: ct and flash OFF (Disable) (Press key to select OFF/ON)	ct - OFF ct
Short Press [UNIT] Key	6. Cycle to another unit % and flash ON	PC - ON %
Short Press [PRINT] Key	7. Display unit signal % and flash OFF	PC - OFF %
	○ Repeat Step 6-7 can change unit on/off one by one as follow: ct, %, kg, /AVR, T/AVR, T, tIH, tIs, tIT, dr, lb, GN, dwt, ozt, oz	
	○ The default setting is all units was turn on.	
Short Press [CAL] Key	8. Confirm the setting of unit and return	--UNIT-
Short Press [TARE] Key Two Times	9. Finish setting and return to standby	

Note: The grey color words explain the signal's meaning which flash on the window.

Correct Temperature

Operator can set the display temperature by setting menu.

Instance

Key (Order)	Step Explanation	LCD Screen Display
Press and Hold [MENU] Key	1. Display Menu	--BASE-
Short Press [CAL] Key	2. Enter Into Setting Menu	-SCALE-
Short Press [MENU] Key Two Times	3. Enter Into Correct Temperature Mode	TRD 00
	○ Operator can set temperature by : Press [UNIT] key to move cursor and press [PRINT] to cycle and select number.	
	○ It only can adjust the machine's temperature and the adjustment range is within ± 1.9	
Short Press [CAL] Key	4. Confirm the temperature and return	--BASE-
Short Press [TARE] Key	5. Finish the setting and return to standby	

LED Brightness Setting

Operator can turn on/off/auto backlight by setting menu.

Instance (Example: F series)

Key (Order)	Step Explanation	LCD Screen Display
Press and Hold [MENU] Key	1. Display the menu	--BASE-
Short Press [CAL] Key	2. Enter into setting menu	-SCALE-
Short Press [MENU] Key Three Times	3. Enter into brightness setting and flash 2	LED---2
Short Press [PRINT] Key	4. LED became brighter and flash 3	LED---3
	○ Short press [PRINT] or [UNIT] key can circle and select brightness from 1 to 3.	
Short Press [CAL] Key	5. Confirm the LED brightness setting and return	--BASE-
Short Press [TARE] Key	6. Return to the standby	

Note: The grey color words explain the signal's meaning which flash on the window.

Backlight On/Off Setting (T Series Instance)

Key (Order)	Step Explanation	LCD Screen Display
Press and Hold [MENU] Key	1. Display the menu	--bA5E-
Short Press [CAL] Key	2. Enter into tetting menu	-SCALE-
Short Press [MENU] Key Three Times	3. Start to set backlight and flash ON (Enable)	bl -- ON
Short Press [PRINT] Key	4. Flash OFF and turn off the backlight (Disable)	bl -- OFF
Short Press [PRINT] Key	5. Flash AUT and backlight will turn on or off automatically	bl -- Aut
Short Press [CAL] Key	6. Confirm the backlight setting and return	--bA5E-
Short Press [TARE] Key	7. Return to the standby	

Buzzer On/Off Setting

Operator can turn on/off the buzzer sound by setting menu.

Instance

Key (Order)	Step Explanation	LCD Screen Display
Press and Hold [MENU] Key	1. Display Menu	--bA5E-
Short Press [CAL] Key	2. Enter Into Setting Menu	-SCALE-
Short Press [MENU] Key Four Times	3. Enter into buzzer setting and flash "ON"	BEEP ON
Short Press [PRINT] Key	4. Turn off buzzer and flash "OFF"	BEEP OFF
Short Press [CAL] Key	5. Confirm the buzzer setting and return	--bA5E-
Short Press [TARE] Key	6. Finish the setting and return to standby	

Note: The grey color words explain the signal's meaning which flash on the window.

Dormancy and Power Saving Setting (Not available for T series)

User can enter into the menu and set the machine's fast dormancy time.

Instance (Example: F series)

Key (Order)	Step Explanation	LCD Screen Display
Press and Hold [MENU] Key	1. Display the menu	--bA5E-
Short Press [CAL] Key	2. Enter into the setting menu	-SCALE-
Short Press [MENU] Key Six Times	3. Start to set fast dormancy time and flash 0 (Enable)	SLEEP-0
Short Press [PRINT] Key	4. Set the time and flash 1	SLEEP-1
	<i>○ Short press [PRINT] or [UNIT] key can circle and select dormancy time from 0 to 9 seconds.</i>	
Short Press [CAL] Key	5. Confirm the dormancy setting and return	--bA5E-
Short Press [TARE] Key	6. Return to the standby	

Power On Self Test Setting (POST)

User can enter into the menu to turn on or off the Power On Self Test of voltage and temperature.

Instance

Key (Order)	Step Explanation	LCD Screen Display
Press and Hold [MENU] Key	1. Display the menu	--bA5E-
Short Press [CAL] Key	2. Enter into the setting menu	-SCALE-
Short Press [MENU] Key Seven Times	3. Start to set POST and flash 0 (Not display POST)	POST--0
Short Press [PRINT] Key	4. Change the setting and display 1(Display POST)	POST--1
Short Press [CAL] Key	5. Confirm the POST setting and return	--bA5E-
Short Press [TARE] Key	6. Return to the standby	

Note: The grey color words explain the signal's meaning which flash on the window.

Communication Function Setting (Optional)

Purpose

Operator can select the communication way by setting the menu.

Baud Rate Setting

Select different baud rate for different output required.

Machine ID No. Setting

For recognize each machine by different ID No.

FMT Setting (Transfer the Signal)

Select the menu and switch the signal from computer to other equipment (such as printer), or send signal to both at the same time.

COM Setting (Communication Way)

Select different communication way for output different signal.

COM ITEM (To Turn On/Off the Communication Data) (Optional)

Operator can turn on or off the any out put RS232 data.

PRT ITEM (To Turn On/Off the Printing Data) (Optional)

Operator can turn on or off the any out put printing data.

Instance

Key (Order)	Step Explanation	LCD Screen Display
Press and Hold [MENU] Key	1. Display the menu	--bRSE--
Short Press [MENU] Key	2. Enter into the setting menu	--[oññ--
Short Press [CAL] Key	3. Start to set the Baud rate ○ Press [PRINT] key and select different baud rate in turns: 12: 1200bps, 24: 2400bps, 48: 4800bps, 96: 9600bps	bRud-96
Short Press [MENU] Key	4. Enter into Machine ID Setting ○ Operator can set Machine ID from 001 to 255, Press [UNIT] key to move the cursor and press [PRINT] key to select the number.	Id--001
Short Press [MENU] Key	4. Output data way setting ○ Press [PRINT] key can select: KEY.COM, KEY.PRT Short Press [CAL] key to select KEY.COM and return: Machine send signal to computer when press [PRINT] key. Short Press [CAL] key to select KEY.PRT and return: Machine send signal to printer when press [PRINT] key.	Fñt-[oñ
Short Press [MENU] Key	4. Enter Into Communication Way Setting ○ Press [PRINT] key can select: NON: Disable the data output, CON: output data continuously, STY: output data while steady, KEY: output data only by press [PRINT] key, SOFT: output data by Software, Txxx: output data every XX seconds (Can set time manually).	[oñ KEY
Short Press [MENU] Key	4. Turn On/Off the communication data Setting	[oñ tEñ
Short Press [MENU] Key	4. Turn On/Off the printing data Setting ○ Please refer to pages 20-21 to know detail operating steps.	Pr tEñ
Short Press [CAL] Key	5. Confirm the setting and return	--[oññ--
Short Press [TARE] Key	6. Return to the Standby	

●The grew color parts is the following operation after Step 1-3 baud rate Setting.

Note: The grey color words explain the signal's meaning which flash on the window.

COM ITEM Instance

Key (Order)	Step Explanation	LCD Screen Display
Press and Hold [MENU] Key	1. Display Menu	--bA5E-
Short Press [MENU] Key	2. Enter into Communication Setting	--[com]-
Short Press [CAL] Key	3. Enter into Baud rate Setting	bAud-96
Short Press [MENU] Key Four Times	4. Enter into output data turn On/Off menu	[com] tEñ
Short Press [CAL] Key	5. Enter into turn On/Off output data of Type	TYPE ON
	<ul style="list-style-type: none"> ○ The default setting is turn ON and output all machine's data. Operator can press [PRINT] to turn OFF each output data. ○ Short press [UNIT] key can go back to set the previous parameter. 	
Short Press [MENU] Key	6. Enter into turn On/Off output data of ID	Id ON
Short Press [MENU] Key	7. Enter into turn On/Off output data of Temperature	TEmp ON
Short Press [MENU] Key	8. Enter into turn On/Off output data of Battery Status	POW ON
Short Press [MENU] Key	9. Enter into turn On/Off output data of Weighing Mode	mode ON
Short Press [MENU] Key	10. Enter into turn On/Off the application (AUX) menu	AUX ON
Short Press [MENU] Key	11. Enter into turn On/Off output data of Reference Weight Mass	rEF ON
Short Press [MENU] Key	12. Enter into turn On/Off output data of Weighing Status	STAT ON
Short Press [MENU] Key	13. Enter into turn On/Off the alarm ALR menu	ALr ON
Short Press [MENU] Key	14. Enter into turn On/Off output data of Tare Status	TAr ON
Short Press [MENU] Key	15. Enter into turn On/Off output data of Zero Status	ZEro ON
Short Press [CAL] Key	16. Confirm the setting and return	[com] tEñ
Short Press [TARE] Key Two Times	17. Finish the setting and return to standby	

Note: The grey color words explain the signal's meaning which flash on the window.

PRT ITEM Instance

Key (Order)	Step Explanation	LCD Screen Display
Press and Hold [MENU] Key	1. Display Menu	--bA5E-
Short Press [MENU] Key	2. Enter into Communication Setting	--[com]-
Short Press [CAL] Key	3. Enter into Baud rate Setting	bAud-96
Short Press [MENU] Key Five Times	4. Enter into output data turn On/Off menu	Prnt tEñ
Short Press [CAL] Key	5. Enter into turn On/Off output data of Type	TYPE ON
	<ul style="list-style-type: none"> ○ The default setting is turn ON and output all machine's data. Operator can press [PRINT] to turn OFF each output data. ○ Short press [UNIT] key can go back to set the previous parameter. 	
Short Press [MENU] Key	6. Enter into turn On/Off output data of ID	Id ON
Short Press [MENU] Key	7. Enter into turn On/Off output data of Temperature	TEmp ON
Short Press [MENU] Key	8. Enter into turn On/Off output data of Battery Status	POW ON
Short Press [MENU] Key	9. Enter into turn On/Off output data of First Dividing Line	-- ON
Short Press [MENU] Key	10. Enter into turn On/Off output data of Weighing Mode	mode ON
Short Press [MENU] Key	11. Enter into turn On/Off the application (AUX) menu	AUX ON
Short Press [MENU] Key	12. Enter into turn On/Off output data of Reference Weight Mass	rEF ON
Short Press [MENU] Key	13. Enter into turn On/Off output data of Weighing Status	STAT ON
Short Press [MENU] Key	14. Enter into turn On/Off the alarm ALR menu	ALr ON
Short Press [MENU] Key	15. Enter into turn On/Off output data of Tare Status	TAr ON
Short Press [MENU] Key	16. Enter into turn On/Off output data of Zero Status	ZEro ON
Short Press [MENU] Key	17. Enter into turn On/Off output data of Weight	wEt ON
Short Press [MENU] Key	18. Enter into turn On/Off output data of Second Dividing Line	---- ON
Short Press [MENU] Key	19. Enter into turn On/Off output data of Signature	SIGN ON
Short Press [CAL] Key	20. Confirm the setting and return	[com] tEñ
Short Press [TARE] Key Two Times	21. Finish the setting and return to standby	

Note: The grey color words explain the signal's meaning which flash on the window.

Print Data of Weighing Mode

● Instance: F-A2000g/0.01

TYPE:20002	Machine Type
ID:1	Identification
TEMP:20.8C	Room Temperature
BAT:FULL(EXT)	Power Status
MODE:NORMAL	Mode
AUX:xxx	Application Status
REF:1000.00g	Calibration Weight Mass
STATUS:STEADY	Present Status
ALR:xxx	Present Alarm Status
TARE:NONE	Tare Status
ZERO:NATURAL	Zero Status
WT:0.00g	Weighing Result
SIGNATURE:	Signature
	Blank

● Instance: T-A2000g/0.01

TYPE:20002	Machine Type
ID:1	Identification
TEMP:20.8C	Room Temperature
BAT:FULL(EXT)	Power Status
MODE:NORMAL	Mode
REF:1000.00g	Calibration Weight Mass
STATUS:STEADY	Present Status
TARE:NONE	Tare Status
ZERO:NATURAL	Zero Status
WT:0.00g	Weighing Result
SIGNATURE:	Signature
	Blank

Machine Weighing Configuration Setting

Operator can set the machine basic weighing config to change the weighing capability to reach different required.

Zeroing Range Setting

Operator can increase or decrease the zeroing range for they need.

Tracking Range Setting

Operator can increase or decrease tracking range for they need.

Sensitivity Level Setting

Operator can adjust the sensitivity by increase or decrease the level. Level 1 is the lowest sensitivity and level 6 is the highest.

Speed Level Setting

Operator can adjust the weighing response time by increase or decrease the level. Level 1 is the slowest weighing response speed and level 3 is the fastest (Default and recommend setting: Level 2)

Anti-Vibration level Setting

Operator can adjust the weighing response time and anti-vibration strength by increase or decrease the level. The higher level comes with higher anti-vibration. Level 1 has fast weighing speed and weak anti vibration. Level 6 has strong anti vibration and low weighing speed.

Instance

Key (Order)	Step Explanation	LCD Screen Display
Press and Hold [MENU] Key	1. Display the Menu	--BASE--
Short Press [MENU] Key Two Times	2. Enter into Configuration Setting	-SETUP-
Short Press [CAL] Key	3. Enter into Zeroing Range Setting	2Ero-00
	○ Press [PRINT] key can set Zeroing Range from 0.0 to 6.0	
Short Press [MENU] Key	4. Enter into Tracking Range Setting	5tdy-05
	○ Press [PRINT] key can set Tracking Range from 0.0 to 6.0	
Short Press [MENU] Key	4. Enter into Sensitivity Level Setting	SENS--3
	○ Press [PRINT] key can set Sensitivity Level from 1 to 6	
Short Press [MENU] Key	4. Enter into Speed Level Setting	SPEED-2
	○ Press [PRINT] key can set Speed Level I from 1 to 3	
Short Press [MENU] Key	4. Enter into Anti-Vibration Level Setting	FILL--4
	○ Press [PRINT] key can set Anti-Vibration level from 1 to 6	
Short Press [CAL] Key	5. Confirm the setting and return	-SETUP-
Short Press [TARE] Key	6. Finish the setting and return to standby	

●The grew color parts is the following operation after Step 1-3 Zeroing Range Setting.

Note: The grey color words explain the signal's meaning which flash on the window.

Eighth Part: Restore Factory Setting

Restore the machine Config

Purpose

Operator can restore the machine to factory setting by input the code in menu.

Instance

Key (Order)	Step Explanation	LCD Screen Display
Press and Hold [MENU] Key	1. Display Menu	- - n o d E -
Short Press [MENU] Key Four Times	2. Enter Into restore factory setting function	- [o n f i] -
Short Press [CAL] Key	3. Enter Into the input code	[o d 0 0 0 0]
	○ Press [UNIT] key to move the cursor and press [PRINT] key to select the number. THE CODE IS: 8888	
Short Press [CAL] Key	4. Confirm and return to previous menu	- [o n f i] -
Short Press [TARE] Key	5. Finish Setting and return to standby	

- ⚠ Restore the factory setting code is 8888. Operator can not set other code.
Restore the factory setting will make machine lost the every setting.
Don't restore the factory setting if machine without any obviously problem.

Ninth Part: Unit Switching

Unit Switching

Press (UNIT) Key, the weighing unit will cycle between the different weighing units with each press of the button. The balance will default to the last unit used when turned on the next time.

Unit Signal	Unit	Unit Exchange Rate
g	Gram	1
ct	Carat	5
oz	Ounce	0.03527396200
ozt	Troy Ounce	0.03215074700
dwt	Pennyweight	0.64301493100
GN	Grains	15.43235835000
lb	Pound	0.00220462260
dr	Dram	0.56438222222
tlT	Taiwan Tael	0.02666666000
tlS	Singapore Tael	0.02645544638
tlH	Hong Kong Tael	0.02671725000
T	Tola	0.08573532418
T/A/R	tola / anna / rati T.A.R	0 . 01 . 2 . 23
I/A/R	tola / Mna / rati T.M.R	0 . 01 . 0 . 23
kg	Kilogram	0.00100000000

Note: The grey color words explain the signal's meaning which flash on the window.

Tenth: Machine Detail Specification Cable

Item No.	Weighing Range(g)	Readability (mg)	Repeat-ability(mg)	Linearity (mg)	Operate Temp(°C)	Pan Size (mm)	Housing Size (LxWxH)(mm)	Warm-up Time (m)
◆	100	0.1	± 0.1	± 0.2	20 ± 2.5	∅ 80	295x208x290	30-60
◆	200							
◆	300	1	± 1	± 2	20 ± 7.5	∅ 90		10-20
◆	500					∅ 108		

	100							
	200	1	± 2	± 2	20 ± 7.5	∅ 80	295x208x290	10-20
	300							

◆ Fit with RS232 Line, Fit with Under Hook.

Item No.	Weighing Range(g)	Readability (g)	Repeat-ability(g)	Linearity (g)	Operate Temp(°C)	Pan Size (mm)	Housing Size (LxWxH)(mm)	Warm-up Time (m)
	200							
	300							
	500		± 0.01	± 0.02		∅ 133		
	600	0.01			10-35		295x208x88	10-20
	1000							
	2000							
	3000		± 0.02	± 0.03		156x156		

	1000					∅ 133		
	2000							
	3000	0.1	± 0.1	± 0.2	10-35		295x208x88	10-20
	5000							
	6000					168x168		
	10000							
	6000	1	± 1	± 2				

Item No.	Weighing Range(g)	Readability (mg)	Repeat-ability(mg)	Linearity (mg)	Operate Temp(°C)	Pan Size (mm)	Housing Size (LxWxH)(mm)	Warm-up Time (m)
	100							
	200	1	± 2	± 2	20 ± 7.5	∅ 80	295x208x290	10-20
	300							

Item No.	Weighing Range(g)	Readability (g)	Repeat-ability(g)	Linearity (g)	Operate Temp(°C)	Pan Size (mm)	Housing Size (LxWxH)(mm)	Warm-up Time (m)
	200							
	300							
	500		± 0.01	± 0.02		∅ 133		
	600	0.01			10-35		295x208x88	10-20
	1000							
	2000							
	3000		± 0.02	± 0.03		156x156		

	1000					∅ 133		
	2000							
	3000	0.1	± 0.1	± 0.2	10-35		295x208x88	10-20
	5000							
	6000					168x168		
	10000							
	6000	1	± 1	± 2				

Eleventh: Proper Care and Maintenance

Repair

Only trained technician was authorized to repair the problem machine.

Clean

- Pull out the adapter from electrical outlet and cable from machine.
 - Use soft cloth with neutral cleanser to clean the machine housing.
 - Dry the housing with soft cloth and then take out the weighing pan and wash it.
 - When take up the weighing pan and bracket, make sure that don't broken the weighing system.
- ⚠ Do not let the liquid flow into machine.
- ⚠ Do not use the caustic cleanser.

Wash stainless steel surface

Use soft cloth or sponge to clean all stainless steel parts need to clean often and completely. Only home appliances cleanser available for clean the stainless parts. Wipe up the stainless steel parts surface first, wash up all leftover second and then dry it. Oil the stainless steel surface if necessary.

Guarantee

Do not ignore your warranty rights.

If machine have problem in guarantee period, please contact local distributor.

- We carry out The Guarantees strictly according to national regulation
- The guarantee period is one year from the date of sell. The guarantee machine is with correct install and usage, not man-made problem. Send back machine to local distributor or seller with proper packing (include warranty card). We will exchange a new one or repair and return machine to you within one week from we receive it.
- Battery, load cell and Magnetic cylinder is not including in guarantee range.
- If the problem machine exceed the guarantee time limit or was damage by man-made, we will charge the reasonable labor and material cost, delivery cost and any other possible cost.

Product Guarantee Elucidation

We guarantee that under proper using situation, We provide one year repairing service include material and technical support after selling date.

In Guarantee period, if machine broken or damage because of material or techniques, We will repair or replace the problem parts which has been proved. Please contact our Local office when machine need repairing.

The Guarantee Card will be inefficacy with wrong operating and not according as the operating manual. The Guarantee Card will be inefficacy with any damage or broken by unauthorized person's repairing or replacement.

We are not in charge with apparent or intentional disobeying the guarantee rule which cause machine any relevant or accidently broken.