

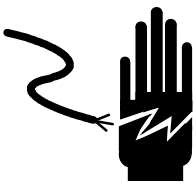





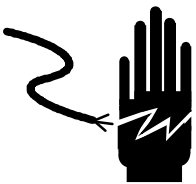

TD - 200

Weighing Indicator Operation Manual

	 WARNING
	<p>Only authorized personnel are allowed to do setting, adjusting & calibration, testing and repairing!</p>

	 WARNING
	<p>Please keep indicator ground connected well!</p>

 ATTENTION
<p>Please cut off power before connecting the indicator to the indicator, computer or any other devices.</p> <p>After all connection done, wait for 30 seconds, and then power on the indicator.</p>

 ATTENTION
<p>This indicator is an electrostatic-sensitive device; please do electrostatic protection during operation and maintenance.</p>

Without permission, any printing, copying or modifying is prohibited.

INDEX

1.0 OVERVIEW.....	5
1.1 TECHNICAL DATA.....	5
1.2 MAIN FUNCTION.....	6
1.3 OUTLINE DIMENSION.....	6
1.4 MODEL NAMING RULE.....	6
2.0 INSTALLATION.....	6
2.1 INSTALLATION AND SETTING.....	7
2.2 PACKING INSPECTION.....	7
2.3 ELECTRICAL CONNECTION.....	7
2.3.1 OPEN INDICATOR.....	7
2.3.2 ANALOG LOAD CELL CONNECTION.....	7
2.3.3 DIGITAL LOAD CELL CONNECTION.....	7
2.3.4 INTERFACE CONNECTION.....	8
2.3.5 POWER CONNECTION.....	8
2.4 INDICATOR SEAL.....	8
3.0 KEYPAD INTRODUCTION.....	9
4.0 FUNCTION KEYS.....	9
5.0 WEIGHING STATUS.....	11
6.0 BASIC OPERATION.....	11
6.1 SWITCH ON AND TURN OFF.....	11
6.2 ZERO.....	11
6.3 TARE.....	12
6.4 TARE CLEAR.....	12
6.6 WEIGHING MODE.....	12
6.7 PRINT DATA.....	16
7.0 MENU OPERATION.....	16
7.1 SETUP.....	17
7.1.2 LOAD CELL TYPE.....	16
7.1.3 CAPACITY AND DIVISION.....	18
7.1.3.1 CAPACITY.....	18
7.1.3.2 DIVISION VALUE.....	19
7.1.4 ZERO CALIBRATION.....	19
7.1.5 CORNER ADJUSTING.....	19
7.1.6 LINEARITY CALIBRATION.....	20
7.1.7 CALIBRATION.....	21
7.1.8 x10 DISPLAY.....	21
7.2 APPLICATIONS.....	21
7.2.1 AUTO ZERO TRACK.....	22
7.2.2 ZERO OPERATION.....	22
7.2.3 TARE SETUP.....	22
7.2.4 MOTION DETECT.....	22
7.2.5 DIGITAL FILTER.....	23

7.2.6 COMMUNICATION.....	23
7.2.7 COM1 (RS232).....	23
7.2.8 SLAVE ADDRESS.....	24
7.2.9 IP SETUP.....	24
7.2.10 BACKLIGHT.....	25
7.3 DATA MANAGEMENT.....	25
7.4 DIAGNOSIS.....	26
7.5 DATE & TIME.....	27
8.0 MENU LIST.....	28
9.0 CONTINUOUS DATA OUTPUT FORMAT.....	29
10.0 CPTZ COMMAND.....	30
11.0 DEFAULT PARAMETER.....	30
12.0 MAINTENANCE.....	31
12.1 DAILY MAINTENANCE.....	31
12.2 PCB BOARD.....	31
12.3 TROUBLE SHOOTING.....	32
12.4 SOFTWARE UPDATE.....	32

** According to the different versions of the software, the descriptions on the display of this menu may not be exactly the same as what it shows on the indicator.*

1.0 Overview

1.1 Technical Data

Accuracy	C3, 10000e degree
Max Resolution	100000d
Display	240X128 dot-matrix LCD with white backlight
Keypad	Digits and letters, navigation, shortcut and on/off
Digital Filtering	Multi-grades filtering
Platform	Analog load cells, Digital load cells <i>Support digital load cell makes of Flintec*, HBM*, Moorange* MARCUS and Avery Berkel*</i> <i>* All rights of those brands belong to those companies who registered and owed.</i>
Load Cell Excitation	Up to 16 load cells
Load Cell Interface	RS485, anti-surge and anti-lightning
Communication port	RS232C and RS485, printer, remote display, computer, etc. Optional of Ethernet, USB, SD card. Optional of Field Bus or Controlling interface
Power	100~240V AC
Protection	IP65
Working Temperature	-10°C ~ 40 °C
Application	Standard weighing 1000 weighing records Reweighting (twice weighing operation) Automatic gross and tare weight identification, 200 temporary records. Preset tare weighing 200 preset tare records
Statistics Report	By date or by truck number
Diagnosis	Serial port self-diagnosis Display self-diagnosis Keypad self-diagnosis

1.2 Main Function

- TD-200 for connection with analog load cells
- TD-200D for connection with digital load cells, like Flintec* RC3D, HBM* C16i, MARCUS* TD150-D, AWT* T301 models
- * All rights of those brands belong to those companies who registered and owed.*
- Load cell communication with isolation and anti-surge technology
- Support manual and automatic corner error adjusting.
- Navigation hint for operation
- 3 modes of truck weighing application
- Indicator data setting with password protection
- English, Pinyin and Numbers input
- Print and query, accumulate all types of statistics reports
- Real-clock
- RS232 and RS485 interface.
- Extend to other industrial communication interfaces
- Self-diagnostic function

1.3 Outline Dimension

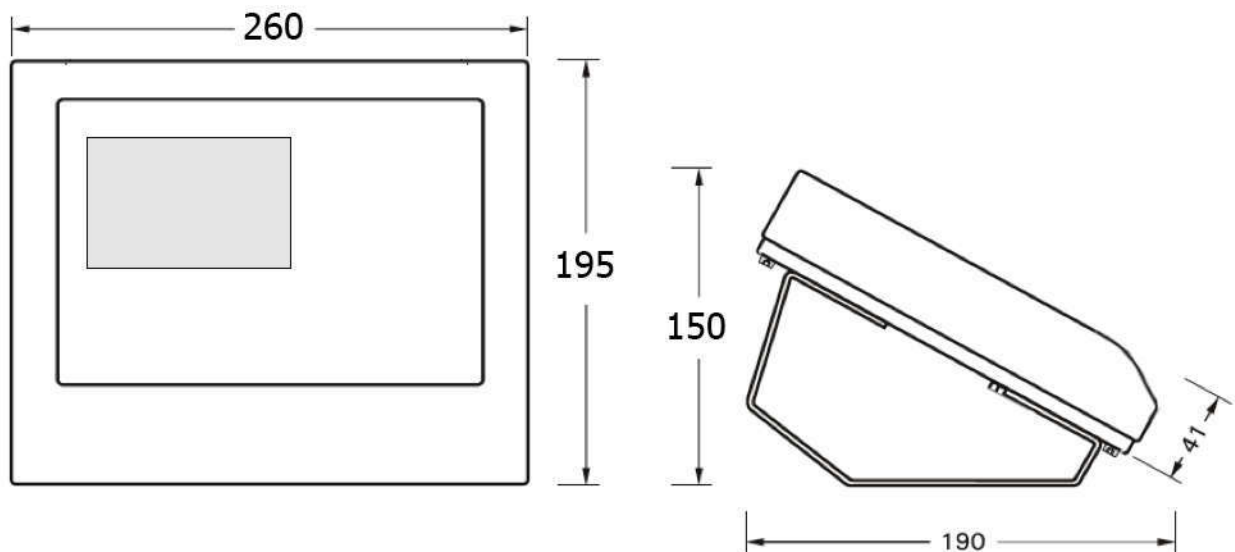

1.4 Model Naming Rule

- | Modell | Description |
|-----------|-------------------|
| ● TD-200 | Analog indicator |
| ● TD-200D | Digital indicator |

2.0 Installation

2.1 Installation and Setting

This chapter introduces how to install and set the indicator. Please read carefully before operation.

2.2 Packing Check

Check all parts well packed and no part missing or damaged, if anything doubt, please contact our technical service department. Take out the indicator if all parts in good condition.

2.3 Electrical Connection

2.3.1 Open indicator

Remove 10 screws on the rear housing and open the indicator.

Attention: Cut off the power before opening indicator, Please adopt electrostatic protection during electrical connection.

2.3.2 Analog Load cell connection

Analog load cell connection uses 7pin terminal J3 on the PCB.

Pin 1	— +EXC	excitation voltage	excitation+
Pin 2	— +SEN	Sense+	
Pin 3	— +SIG	signal+	
Pin 4	— Shield	Shield grounded	
Pin 5	— -SIG	signal-	
Pin 6	— -SEN	Sense-	
Pin 7	— -EXC	excitation-	excitation voltage

! If use 4 wiring load cell, short connect: pin1 and pin2, pin6 and pin7.

2.3.3 Digital load cell connection

Digital load cell connection uses 7 pin terminals J3 and please refer to next page for the connecting ways for different load cells:

ATTENTION:

The shield cable of load cell must be connected to the Shield terminal of the indicator.

HBM C16i

+12V	R+	R-	Shield	T/R+	T/R-	GND
Red	Black	Blue	Shield	Gray	Green	White

Flintec RC3D

+12V	R+	R-	Shield	T/R+	T/R-	GND
White			Shield	Yellow	Green	Brown

Moorange M36D-K

+12V	R+	R-	Shield	T/R+	T/R-	GND
Blue			Shield	White	Red	Black

MARCUS TD150-D

+12V	R+	R-	Shield	T/R+	T/R-	GND
Red			Shield	Green	White	Black

Zemic DHM9Bd10

+12V	R+	R-	Shield	T/R+	T/R-	GND		
Red			Shield	Green and Yellow	White and Brown	Black		

Avery Weigh-Tronix T301

+12V	R+	R-	Shield	T/R+	T/R-	GND
Green			Shield	White	Red	Black

CAS WBK

+12V	R+	R-	Shield	T/R+	T/R-	GND
Red			Shield	Green	Blue	White

2.3.4 Interface connection

RS485 interface

As right picture, wiring according to optional board.

Pin 1 — B RS485 transmitting-
Pin 2 — A RS485 transmitting+

RS232 interface

As right picture, wiring according to optional board.

Pin 3 — GND Grounding
Pin 4 — RXD Receiving
Pin 5 — TXD Transmitting

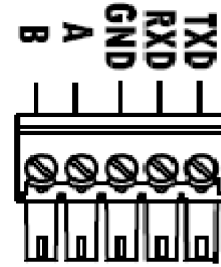

2.3.5 Power connection

Power connection uses 3 pin terminals.

Pin 1 — L
Pin 2 — N
Pin 3 — Ground



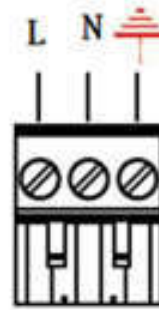







Attention : Input power 100V~240VAC





2.4 Indicator Seal

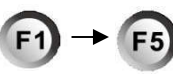

After indicator setting and calibration, use the lead seal or other sealing component to lock the indicator.

3.0 Keypad introduction









	On/off: switch on or turn off the indicator
	OK: act as confirmation during menu operation or digits/letters input
	UP: scroll up the cursor during menu operation
	DOWN: scroll down the cursor during menu operation
	EXIT: during menu operation or letter/number inputting, act as exit.
Edit	EDIT: edit key
	TARE/TARE CLEAR: during gross weighing, press this key to make weight as tare value, indicator shows “0”. During net weighing, press this key to remove the tare value, back to the gross weight.
	CANCEL: act as backspace key during inputting, to delete the wrong input
	ZERO: during gross weighing, press this key to zero the scale and the zero indication light on.
	PRINT: print the current weight or assigned data, the data will be recorded at the same time.
	NUMBERS: input time, truck numbers, etc. Input the letter during words or Chinese Character input.
	DECIMAL POINT: input the decimal point during number typing.
	FUNCTION KEYS: different functions in different interface, showing different operation according to the corresponding icons on the display.

4.0 Function keys

	Weighing Modes: exchange among 1 st weighing, 2 nd weighing, preset tare weighing, normal weighing modes.
	Weighing Records Statistics: aggregation per truck number, date, tare value, temporary aggregation.

	Truck Number Input
	Cargo Number Input
	Parameter Setting

5.0 Weighing Status

	 Net weighing icon.
	 Gross weighing icon.
	 The scale in dynamic status (unstable)
	 The scale in stable status
	 When the scale is in zero range (0 or 0 ±1/4d).
	 When the scale is not in zero range.

6.0 Basic operation

6.1 Switch on and turn off

Press on/off key, the indicator will display our company's slogan of Value Each Gram and version number and then enter the main display:

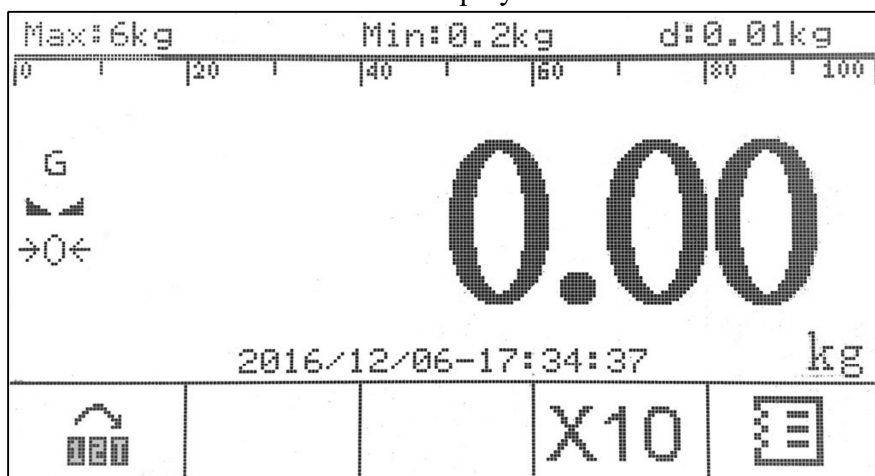

Press on/off key for 2 seconds or more, the indicator will be turned off

6.2 Zero

➤ ZERO UPON POWER ON

If the zero upon power on is active and the weight value within the range of the auto zero, the scale will be zero upon power on and the zero icon light on.

SET: Main Menu – Application – Zero Operation – 2 .Power Up Zero

➤ MANUAL ZERO

Press key to zero the scale (the weight value must be within the range of zero)

SET: Main Menu – Application – Zero Operation – 1. Key Zero

Attention: It can't do zero with the below status:

- A. Dynamic display (unstable)
- B. Key zero disabled.
- C. Weight read out of the zero range.

6.3 Tare

During gross weighing, press key, the current weight will be saved as tare weight and the NET icon light on.

Attention: When the scale in net weighing or the reading is dynamic, it can't do tare operation.

6.4 Tare clear

During net weighing, press key, it will remove the tare value, and the indicator back to gross weighing.

6.5 Type method

➤ Exchange among English/Pinyin/Number Input:

Press F5 to change IMS among NUM (number), EN (English) and Pinyin

Number Input: Just press the number keys

Letter Input: Shift to EN, press number keys for right times to get the letter appears, example of Ch input: press key for 3 times and it will show C, and press key for 2 times, it will show h.

Signs Input: In letter input mode, press 0 to get () / | \ % * - , etc.

Pinyin Input: no description for exporting versions.

VH No.: 17_				NUM
				IMS

6.6 Weighing mode

It has 4 weighing modes: 1st weighing, 2nd weighing, preset tare weighing and normal weighing mode

1st Weighing:



During weighing interface, press F1 to enter weighing mode choose

WEIGH MODE SELECT				
1 st WEIGH 2 nd WEIGH PRE TARE NORMAL WEIGH DATA STATICS				

Press the function key F1 to choose the weighing mode.

Truck Number Input:

Press function key of  (F3) to input truck number (number, letter or Chinese Character (10 numbers or letters, 1 Chinese Character = 5 numbers/letters), press F5 can swift between NUM (number) / EN (English letter) / Pinyin

VH No.: 7EN652_				
				NUM
				IMS

Press OK to confirm after truck number input.

Truck Number Input:

Press function key of  (F4) to input the cargo number (support number/letter)

GOODS No.: APPLE_				
				EN
				IMS

Press OK to confirm after cargo number input

Press  key to save the first weighing data.

Attention: If the weight data already saved, it will show repeat, press OK to back)

2nd Weighing:

During weighing interface, press F1 to enter weighing mode choose



WEIGH MODE SELECT

1st WEIGH | 2nd WEIGH | PRE TARE | NORMAL WEIGH | DATA STATICS

Press F2 to choose 2nd WEIGH

Press  key to print the weighing data

S/N.	Date	Time	Truck No.	Cargo No.	G.W.	TARE	NET
0001	2016/03/13	08:09:01	7EN652	Steel	15000kg	5000kg	10000kg

Preset Tare Weighing:

During weighing interface, press F1 to enter weighing mode choose



WEIGH MODE SELECT

1st WEIGH | 2nd WEIGH | PRE TARE | NORMAL WEIGH | DATA STATICS

Press F3 to choose PRE TARE

In this mode, when put truck no., it will retrieve the tare weight of this truck and it will do TARE automatically and the indicator will display the net weight.

** If the tare weight of this truck stored in the indicator already, if no data stored, input the new tare weight value by F4 key and press OK to store it.*

** If the tare weight of this truck already stored in the indicator, when you press F4 key to input a new tare value, it will indicate whether the tare value needs to be modified or not, press OK to overwrite the data or press ESC to quit.*

Normal Weighing:

During weighing interface, press F1 to enter weighing mode choose



WEIGH MODE SELECT

1st WEIGH | 2nd WEIGH | PRE TARE | NORMAL WEIGH | DATA STATICS

Press F4 to choose NORMAL WEIGH

If the 1st weigh, 2nd weigh and Preset Tare weighing are not needed, you can choose this stand weighing mode, during this mode, you can input the truck number, cargo number, and you can do tare operation by pressing TARE key, and press PRINT key to print and store the data.

Data Statistics Report:

During weighing interface, press F1 to enter weighing mode choose



WEIGH MODE SELECT

1st WEIGH | 2nd WEIGH | PRE TARE | NORMAL WEIGH | DATA STATICS

Press F5 to choose DATA STATICS

SUMMARY MODE SELECTION

VH No. | DATE | |VH No.& TARE TB| 1st TMP TB

Press F1 to choose the statistics report per truck number, and press F2 to choose the statistics report per date. The operation is similar and now takes the example of report per date:

Input the date (format of year/month/day) and then press OK to query the data per the date.

Date: 2016/03/15

Total 2 Records

Total Net Weight: 19000kg

Total Gross Weight: 25000kg

PRINT TOTAL | PRINT DETAIL LIST | | |

If choose PRINT TOTAL, it will print the report as below:

Summary Report

Date: 2016/03/15	Add times: 2
Total gross weight: 25000kg	Total net weight: 19000 kg

If choose PRINT DETAIL LIST, it will print the report with detailed list of each record:

Summary Report

S/N.	Date	Time	Truck No.	Cargo No.	G.W.	TARE	NET
0001	2016/03/14	08:09:01	7EN652	Steel	9000kg	3000kg	6000kg
0002	2016/03/15	13:05:06	7EN652	Steel	16000kg	3000kg	13000kg

Total gross weight: 25000kg	Total net weight: 19000 kg
-----------------------------	----------------------------

** If you want to check the detailed data of each weighing record on the display of the indicator, please refer to the chapter of MAIN MENU-5 DATA MGT-1 QRY BY VH No. or 2 QRY BY TIME*

6.7 Print data

On normal weighing status, press  key to print the weigh bill and store the weight to the database, there are three formats of weighing bill, set by:

Main Menu – COMMUNICATION – COM1 (RS232) – TICKET FORMAT

Attention: only serial port output is set with print mode, it can do print operation

7.0 Menu operation

Press F5  to enter main menu set:

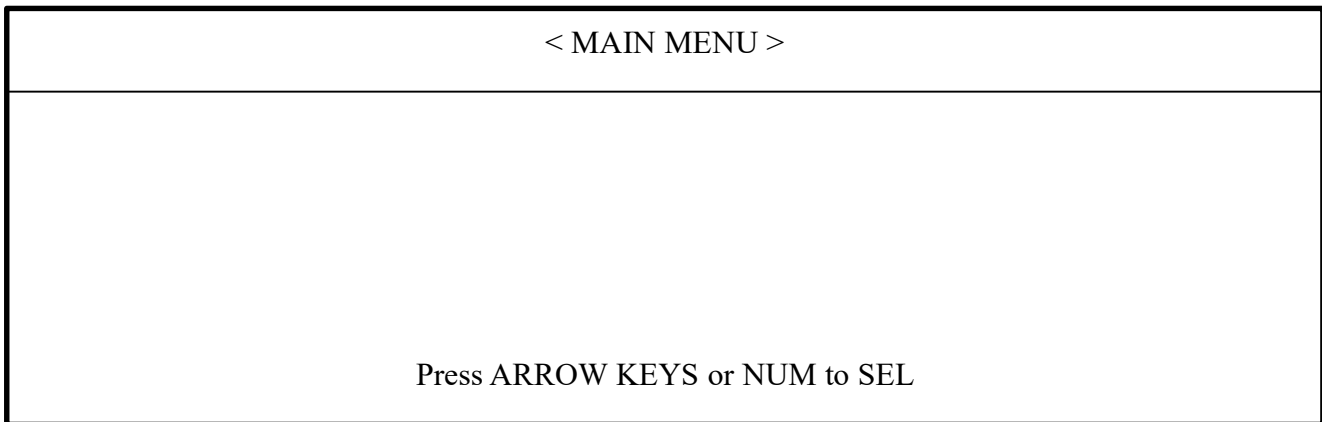

Press the arrow keys or number 1-8 to select the menu and press OK to enter.

** After parameter set and back to the weighing mode, the indicator will ask to save the data by pressing OK key or quit without save by pressing ESC key.*

7.1 Setup

Press the arrow keys or number keys to select the menu and press OK to enter, after setup, press OK to save the data or press ESC to quit without save.

< SETUP >
Press ARROW KEYS or NUM to SEL

7.1.1 Unit

< UNIT >
Press ARROW KEYS or NUM to SEL

7.1.2 Load Cell Type

< CELL TYPE >
Press ARROW KEYS or NUM to SEL

If select the analog cell, no further step for CELL TYPE
If select the digital cell, there are following more steps to set:

< DIGITAL CELL SETUP >
Press ARROW KEYS or NUM to SEL

For the QUANTITY, just input the quantity of the load cells to be used.

For the PROTOCOL, for the moment, we are supporting the below ones:

< PROTOCOL >
Press ARROW KEYS or NUM to SEL

** All rights of those brands belong to those companies who registered and owed.*

< ADDRESS >
1. 010483248 2. 010483249 3. 010483250 4. 010483251 ...
Press ARROW KEYS or NUM to SEL

** The 1st number is the address of the load cell and the following number is the S/N of the load cell.*

** Choose the load cell and press OK; you can set the S/N of it.*

** The number of the address here decided by the QUANTITY set.*

Below is the chart of the addresses of the load cells in the weighbridge, easy for corner adjusting:

1	3	5	7	9	11
2	4	6	8	10	12

Check the internal code of the load cells:

< CELL OUTPUT >
1. 42241 2. 61354 3. 64557 4. 54457 ...
Press ESC to return

7.1.3 Capacity and Division

< CAPACITY & INCREMENT >
1. CAPACITY 2. INCREMENT 3. SEC. CAPACITY
Press ARROW KEYS or NUM to SEL

7.1.3.1 Capacity

< CAPACITY >
CAPACITY: 6000 kg
Press OK to MOD, ESC to RET

7.1.3.2 Division value

< INCREMENT >	
INCREMENT:	2 kg
Press OK to MOD, ESC to RET	

Set up division value of scale, verifying division = d
 d = 0.01, 0.02, 0.05, 0.1, 0.2, 0.5, 1, 2, 5, 10, 20, 50, 100, 200, 500, 1000, 2000, 5000
 Resolution = Capacity/Division
 Max. resolution = 60,000 and Min. resolution = 100.
** and it must be integral multiple of 100.*

< SEC. CAPACITY >	
SEC CAPACITY:	3000 kg
Press OK to MOD, ESC to RET	

7.1.4 Zero calibration

<p>ZERO</p> <p>PLEASE CLEAR THE PLATFORM</p> <p>Press OK to continue Press ESC to return</p>	<p>Empty Scale Sampling</p>
--	-----------------------------

Press OK to calibrate zero point, and it will show Empty Scale Sampling for zero calibration.

7.1.5 Corner Adjusting

Available only for digital load cells, with two ways by manual or automatic, and this operation must be done before calibration.

< ANGULAR SHIFTS >	
<p>1. MANUAL 2. AUTOMATIC COR 3. AUTOMATIC SEC</p> <p>Press ARROW KEYS or NUM to SEL</p>	

If Manual selected:

Select the load cell and press OK to modify,

< AUTOMATIC COR >	< AUTOMATIC COR >
Clear the scale firstly Press OK to start zero calibration Please ESC to quit	Empty scale sampling...

It displays below after the zero calibration:

Load On Load Cell 1	< AUTOMATIC COR >
Put on 10%F.S. (or more) weight Press OK to start Please ESC to quit	Cornering coefficient being calculated...

It will indicates to put the weight on load cell 2 after the load cell 1 adjusted well, do all the adjust one by one.

** Put the weight on or nearby the corner of the load cell to be adjusted.*

7.1.6 Linearity Calibration

The indicator can do linearity calibration (3 points), if YES selected, there will be two loading value during calibration

< LINEAR >
1. NO 2. YES
Press ARROW KEYS or NUM to SEL

7.1.7 Calibration

Zero Calibration

1. ZERO	1. ZERO
PLS Clear the platform Press OK to start zero calibration Please ESC to quit	Empty scale sampling...

Capacity Calibration

2. IN LOAD	2. LOAD
Input Weight: Kg In 20% - 100% Capacity Press OK to continue Please ESC to quit	Load Sampling...

** If the test weight less than 20%, it will indicate Load is too light.*

** It's recommended that 60%-100% test weights to be used for calibration*

** If linearity calibration selected, it will do calibration of high value firstly and then low value.*

7.1.8 x10 Display

The indicator with the function of 10 times display, it's used for internal test and default set of prohibited, it can display higher resolution, example:

Standard display: **40.96**

x10 display: **40.958**

7.2 Applications

< APPLICATION >	
1. ZERO TRACK 2. ZERO OPR 3. TARE OPR	4. MOT DETECT 5. DIGITAL FLITER
Press ARROW KEYS or NUM to SEL	

7.2.1 Auto Zero Track

< ZERO TRCK >	
1. DISABLE	3. 1.0 d
2. 0.5d	4. 3.0 d
Press ARROW KEYS or NUM to SEL	

7.2.2 Zero Operation

< ZERO OPERATION >
Press ARROW KEYS or NUM to SEL

** The zero range can be selected by disable, 10%F.S. or 20%F.S.*

7.2.3 Tare Setup

< TARE SETUP >
Press ARROW KEYS or NUM to SEL

7.2.4 Motion Detect

< MOTION DETECT >	
1. DISABLE	3. 1.0 d
2. 0.5d	4. 3.0 d
Press ARROW KEYS or NUM to SEL	

7.2.5 Digital Filter

< DIGITAL FILTER >
Press ARROW KEYS or NUM to SEL

7.2.6 Communication

< COMMUNICATION >
Press ARROW KEYS or NUM to SEL

* COM1 and COM2 with the same setting and here only describe the COM1

7.2.7 COM1

< COM1 (RS232) >								
<table style="width: 100%; border: none;"> <tr> <td style="width: 50%;">1. BANDRATE</td> <td style="width: 50%;">5. TICKET FORMAT</td> </tr> <tr> <td>2. DATABIT</td> <td>6. TICKET TITLE</td> </tr> <tr> <td>3. PARITY</td> <td>7. OUTPUT PARITY</td> </tr> <tr> <td>4. OUTPUT MODE</td> <td></td> </tr> </table>	1. BANDRATE	5. TICKET FORMAT	2. DATABIT	6. TICKET TITLE	3. PARITY	7. OUTPUT PARITY	4. OUTPUT MODE	
1. BANDRATE	5. TICKET FORMAT							
2. DATABIT	6. TICKET TITLE							
3. PARITY	7. OUTPUT PARITY							
4. OUTPUT MODE								
Press ARROW KEYS or NUM to SEL								

Detailed setting:

- | | | | | | |
|----------------|-------------|---------------|-------------|---------------|-------------|
| BANDRATE: | 1. 1200b/s | 2. 2400b/s | 3. 4800b/s | 4. 9600b/s | 5. 19200b/s |
| DATBIT: | 1. 7BIT | 2. 8BIT | | | |
| PARITY: | 1. NONE | 2. ODD | 3. EVEN | | |
| OUTPUT MODE: | 1. DISABLE | 2. CONTINUOUS | 3. PRINT | 4. MODBUS RTU | |
| TICKET FORMAT: | 1. FORMAT A | 2. FORMAT B | 3. FORMAT C | 4. FORMAT D | |
| TICKET TITLE: | | | | | |
| OUTPUT PARITY: | 1. NO | 2. YES | | | |

Format A:

TD-200
WEIGH BILL
S/N. 10
TIME: 12:00:30
DATE: 2016/03/15
TRUCK No.: 7EN652
CARTO No.: Steel
G.W.: 1500 kg
Tare: 500 kg
NET: 1000 kg

Format B:

S/N.	Date	Time	Truck No.	Cargo No.	G.W.	TARE	NET
1	2016/03/14	08:09:01	7EN652	Steel	9000kg	3000kg	6000kg

Format C:

S/N.	Date	Time	Truck No.	Cargo No.	G.W.	TARE	NET
1	2016/03/15	13:01:01	7EN652	Steel	12000kg	3000kg	9000kg
2	2016/03/15	13:05:06	7EN652	Steel	16000kg	3000kg	13000kg

** The title of this format to be printed only when with the 1st printing after the indicator power on.*

7.2.8 Slave Address

< SLAVE ADDRESS >

ADDRESS: 0

Press OK to MOD, ESC to RET

7.2.9 IP SETUP

< IP SETUP >

Press ARROW KEYS or NUM to SEL

*IP: 192.168.1.111

*MARK: 255.255.255.0

*GATEWAY IP: 92.168.1.1

Press OK to MOD, ESC to RET

7.2.10 Backlight

< BACKLIGHT >	
BACKLIGHT:	45
Press OK to MOD, ESC to RET	

7.3 Data Management

< DATA MANAGEMENT >	
1. QRY BY VH No.	4. CLR VH No.&T
2. QRY BY TIME	5. CLR 1 st DATA
3. CLR ALL DAT	
Press ARROW KEYS or NUM to SEL	

7.3.1 Query by truck no.: Input the truck number and press OK to start

Date:	2016/03/15 13:01:01
TRUCK No.:	7EN652
CARGO No.:	STEEL
G.W.:	12000 kg
N.W.:	9000 kg
The 1 st record	
Press OK to Continue, press ESC to Return	

Date:	2016/03/15 13:05:06
TRUCK No.:	7EN652
CARGO No.:	STEEL
G.W.:	16000 kg
N.W.:	13000 kg
The 2 nd record	
Press OK to Continue, press ESC to Return	

Press OK to check the following records, and if the data over, it will shows the total number of records and total net weight:

Total 2 records
 Total Net Weight: 22000kg

Press *OK* to end and return.

7.3.2. Query By Date: Input the date and press *OK* to start, the display info similar like the query by truck number.

7.3.3. Clear All Data

1. YES 2. No

Press *ARROW KEYS* or *NUM* to *SEL*, and press *OK* to confirm.

Attention: It's non recoverable, so please careful of this operation!

7.3.4. Clear Truck Number and Tare

1. YES 2. No

Press *ARROW KEYS* or *NUM* to *SEL*, and press *OK* to confirm.

7.3.5. Clear 1st DATA

1. YES 2. No

Press *ARROW KEYS* or *NUM* to *SEL*, and press *OK* to confirm.

7.4 Diagnosis

< DIAGNOSIS >	
1. CALB VLAUE. 2. COM1 TEST 3. COM2 TEST 4. DISPLAY TEST	5. KEYPAD TEST 6. DEFAULT LOAD 7. SET PIN CODE
Press <i>ARROW KEYS</i> or <i>NUM</i> to <i>SEL</i>	

7.4.1. Check Calibration Value (CALB VALUE)

1. Zero Code 2. Loading Value 3. Sample Value

Press *ARROW KEYS* or *NUM* to *SEL*, and press *OK* to enter, and if the value needs to be modified, please press *OK* and input the new value.

If the linearity calibration selected in the setup menu, it will has 2 more points:

1. Zero Code 2. Low Loading Weight 3. Low Load Sampling Value
 4. High Loading Weight 5. High Load Sampling Value

The operation is the same as above

7.4.2. COM1 Test

Please cut off the power before test, and short connected *RXD* and *TXD* of *COM1*, it will send the signs of 0-9 continuously (to the display), check it's correct or not.

Press any key to quit the test

7.4.3. COM2 Test

Please cut off the power before test, and short connected RXD and TXD of COM1, it will send the signs of 0-9 continuously (to the display), check it's correctly or not.

Press any key to quit the test

< COM2 TEST >			
EXIT		SEND ALL 1	
		SEND ALL 0	

Press F2 to choose transmitting hex bytes 0xFF

Press F3 to choose transmitting hex bytes 0x00

7.4.4. Display Test

The LCD display will light on and off the whole screen, check all dots display well.

7.4.5. Keypad Test

Push the key (except ESC and On/Off) and it will display on the LCD, if not, it's in malfunction; press the ESC key to quit

7.4.6. Default Load

Only when the indicator works not properly, all return to the factory setup.

7.4.7. Set Pin Code

For avoiding the wrong modification or deleting by mistake, you can set the pin/password for the indicator; it can be in numbers, letters or Chinese Characters.

After the pin/password input, press OK to store it.

Or keep the pin/password blank, and then press OK to quit without saving.

Attention: keep record of the pin/password well, or you can't enter main menu

7.5. Date & Time

Enter the new date/time and press OK to confirm the modification

8.0 Menu list

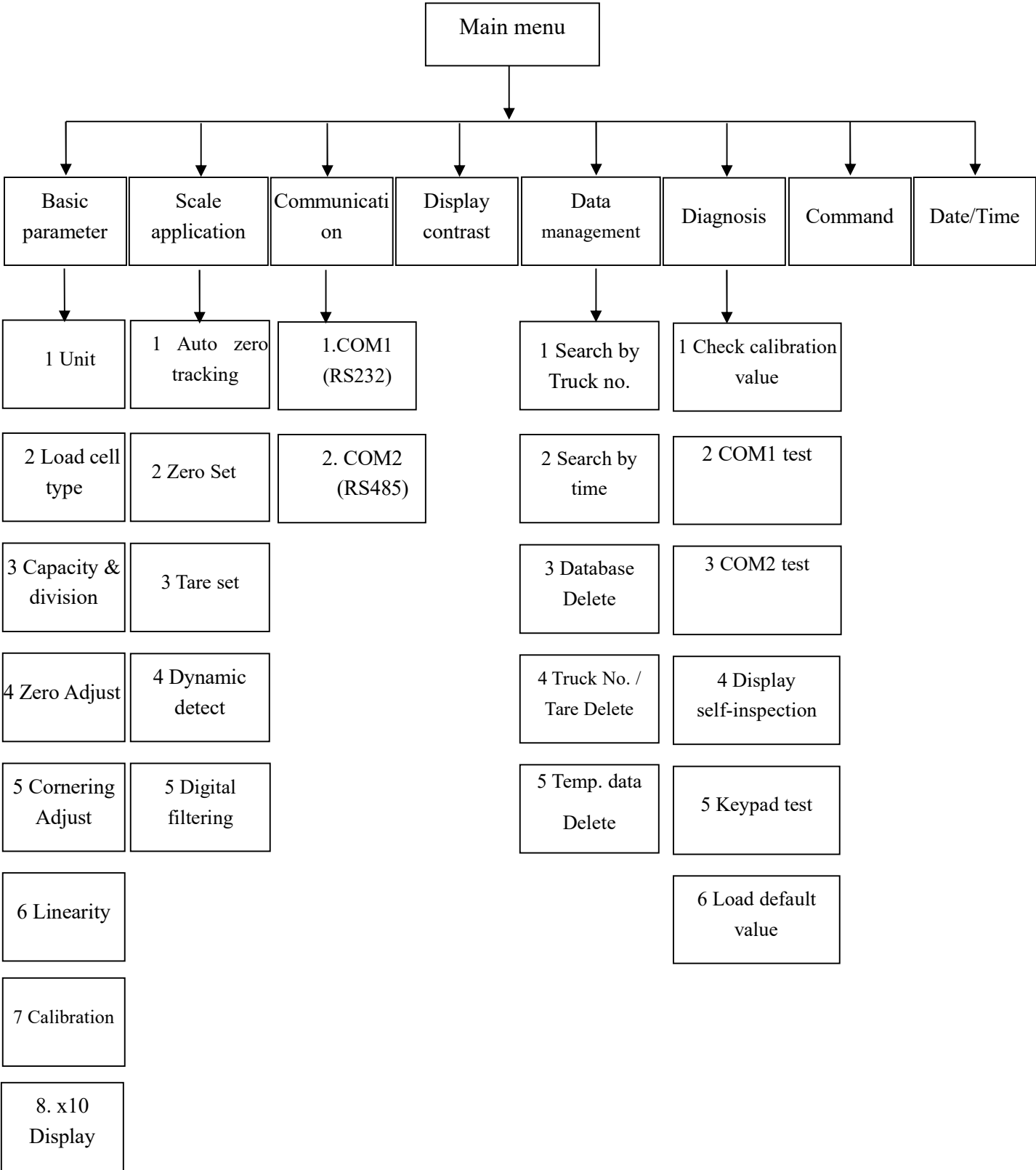

9.0 Continuous Data Output Format

Normally for connecting with remote display or computer:

Continuous output format of 18 Bytes :

Continuous output format																	
STX	A	B	C	X	X	X	X	X	X	Y	Y	Y	Y	Y	Y	CR	CKS
1	2			3						4						5	6

- <STX> ASCII start sign (02H).
- State A,B,C
- Weight G.W or N.W, 6 bits without symbol and decimal point.
- Tare 6 bits without symbol and decimal point.
- <CR> ASCII Enter sign (ODH)。
- <CKS> check and

State A				
Bits 0,1,2				
0	1	2	Decimal point	
0	0	0	XXXX00	
1	0	0	XXXXX0	
0	1	0	XXXXXX	
1	1	0	XXXXX.X	
0	0	1	XXXX.XX	
1	0	1	XXX.XXX	
0	1	1	XX.XXXX	
1	1	1	X.XXXXX	
Bits3,4				
3		4		Division value
1		0		X1
0		1		X2
1		1		X5
Bit5			Constant be 1	
Bit6			Constant be 0	

State B	
Bits	Function
Bit0	G.W.=0,N.W.=1
Bit1	Symbol: +=0, -=1
Bit2	Overload (<0)=1
Bit3	Dynamic=1
Bit4	Unit: kg=1

Bit5	Constant be 1
Bit6	Power on 1
State C	
Bit0	Unit: lb=1
Bit1	Unit: t=1
Bit2	Constant be 0
Bit3	Print command =1
Bit4	Expand display (X10)=1
Bit5	Constant be 1
Bit6	Constant be 0

10.0 CPTZ Command

K3000 serial port set as continuous output and print, at the same time indicator can receive outside device input CPTZ single character command, can easy realize communication between indicator and outside device.

Command as single big character, sent by computer, indicator will operate the command when receive. But no reply value.

Detailed command and meanings:

P – print, indicator will according to set format, print out weight data by serial port.

T – tare, indicator operate tare command. Put current weight as tare to remove.

C – clear tare, indicator operate clear tare.

Z –zero, indicator operate Zero.

11.0 Default Parameter

Parameter	Default	Parameter	Default
1.Scale basic parameter		Serial port 2	RS485
Unit	kg	Baud rate	19200
Load cell type	Analog load cell	Digital bits	8bits
Cap. & division	10000kg,1kg	Check bits	No check bits
Zero adjustment	N/A	Output	Continuous output
Cornering Adjust	N/A	Weight list format	Format A
Linearity Adjust	Forbidden	Print title set	K3000
Calibration	N/A	4.Contrast set	
Expand display	Forbidden	Contrast	45
2. Scale application parameter		5. Data management	
Auto zero Track	±0.5d	Search by truck	
Zero function		Search by time	
Keypad zero	Full capacity ±2%	Database clear	
Power on Zero	Full capacity±10%	Truck/Tare clear	
Tare set	Allow	Temp.data clear	

Dynamic detect	±0.5d	6.Diagnose maintenance	
Digital filtering	Heavy	Check calibration value	
3.Indicator communication parameter		Serial port 1 test	
Serial port1	RS232	Serial port 2 test	
Baud rate	19200	Display diagnosis	
Digital bits	8 bits	Keypad test	
Check bit	No check bit	Load default value	
Output way	Print mode	7.command set	
Weigh bill format	Format A	8.Time set	
Print title set	TD-200		

12.0 Maintenance

12.1 Daily maintenance

Keep clean of the indicator, use cotton cloth with neutral detergent to clean the housing of it.
 Do not use industrial solvent to clean keypad and display.
 Do not spray the solvent onto the indicator directly.
 Do not operate the keys by sharp items.
 Keep regular check and record of the indicator, only authorized personnel allowed.

12.2 PCB board

Key Connectors

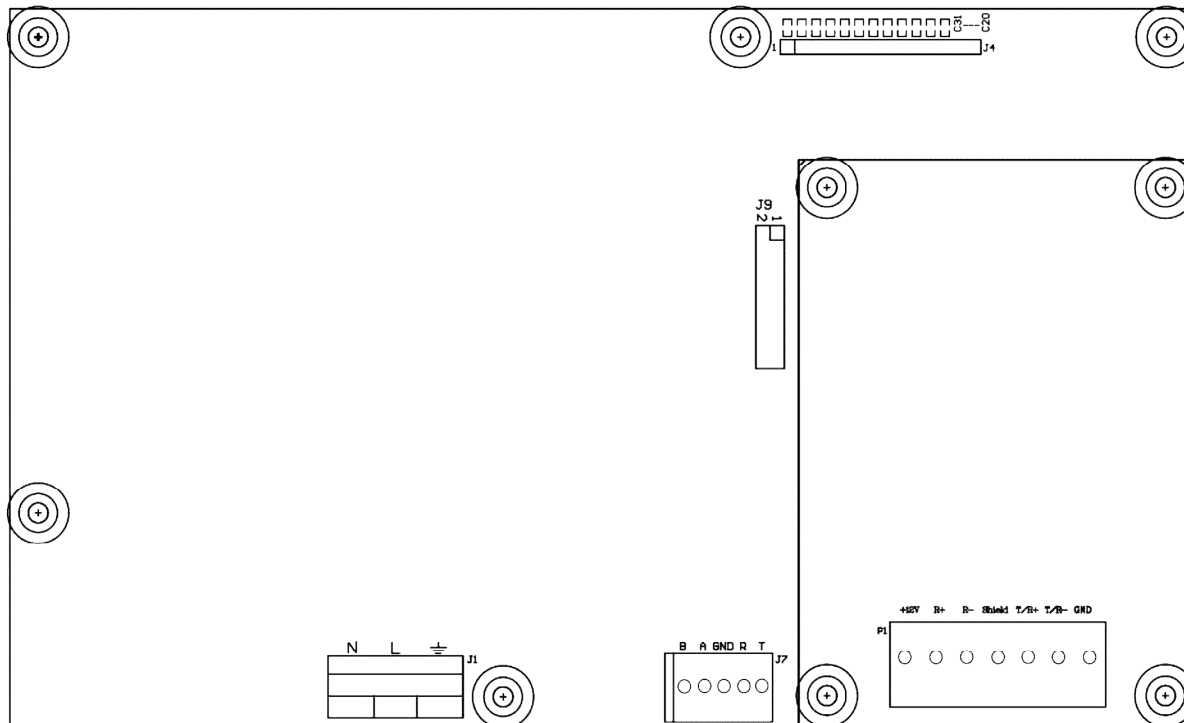

AC socket

RS232/RS485

Load Cell

DIP switch description:

CAL: Down (calibration allowed) , Up (calibration forbidden);

TEST: Default to down

BOOT0: Default to down

12.3 Trouble Shooting

Trouble	Indication	Solution
Overload	Weight > 100%F.S.+9d	Reduce the weight
Under load	Weight < 9d	Press zero
Input weight too big	Test weight input > capacity	Input the correct weight
Input weight too small	Test weight input < 2%F.S.	Input the correct weight
Password failure	Password input wrong	Input the correct password
Weigh record missed	Print 2 nd weighing directly without 1 st weighing	Before 2 nd weighing print, it must do 1 st weighing firstly
Repeat	The truck number appears twice during 1 st weighing	Input the correct number or go to 2 nd time weighing
The weight on the platform must be bigger than 0	There is no load on the platform during 1 st /2 nd print	Load the weight
Cornering calculation fail	Weight on platform not enough	Put enough weight
Empty scale fail	Scale is dynamic (unstable)	Check the scale
Address can't be revised	It appears while modifying the address via the s/n of the cell	Check the cable between indicator and load cell
Calibration not allowed	DIP switch UP	Put DIP switch down
FLASH wrong	FLASH check default	Contact technical dept.
EEPROM wrong	EEPROM check default	Contact technical dept.
Data base wrote wrong	FLASH memory with problem	Contact technical dept.

12.4 Program Update

The software can be updated through the serial port with computer, please contact our technical department.